

# APES - Servo

www.baykal.com.tr



Think Big, We Do.

**PRESS BRAKE**  
technology



**Baykal**

# READY 4.0 CHANGE



Baykal

Baykal

APES 31100  
SERVO





## From Past to *Future*

With a foundation history going back to early 1950s, Baykal today is placed as a leading manufacturer and global supplier of sheet metal working machinery specialising in the production of press brakes, shears, notchers, punching machines, laser cutting systems, plasma cutting machines and Vertical Machining Center.

For its manufacturing operations Baykal utilises three factories which together combine a production area of 60,000 square meters, making it one of Europe's largest facility for sheet metal working and fabricating machinery. The total workforce at Baykal is currently numbered at 650 employees and is composed of highly trained and qualified machine operators and assembly technicians supported by a staff of 50 engineers. All the machines offered by Baykal are designed, manufactured, assembled and finished at Baykal's purpose-built plants in a CAD environment with extensive use of CNC machining and modern workshop equipment.

Baykal Company is accredited for the ISO 9001 Certification issued by the German TÜV institution. Also, since 1995, Baykal has been building machines in conformity with the European CE regulations for safety, being the first Turkish machine-tool manufacturer certified eligible to bear the CE Mark on its products. In addition, all Baykal products are manufactured with the TSE and TSEK quality certificates issued by the Turkish Standards Institution.

Since the last 40 years Baykal has progressed to become a major exporter of sheet metal working machines to the world markets with customers located in all the machine-tool consuming countries of the global geography from Americas to Australia. Baykal is currently represented in over 100 countries worldwide through appointed dealers. In the base market of Turkey, Baykal sheet metal working machines have traditionally commanded a leading market share thanks to the company's pioneering role in the development of Turkey's machine industry and its never-lessening emphasis on quality and service. Here, with a long engineering experience behind, Baykal wishes to present itself as a quality-conscious, professional machine-building company serving the industry.

# APES - Servo

01

**USER FRIENDLY TOUCH SCREEN CONTROL**



02

**MORE THAN 30% HIGHER PRODUCTIVITY**



*Baykal*





03

**%100 ELECTRIC DRIVE**

04

**NO HYDRAULIC OIL**

05

**FULL WORKING LENGTH BACKGAUGE**

# Servo electric technology: innovation first

---

Baykal has applied a servo electric drive system on the new APES-**Servo** press. It is a fast, accurate, non-hydraulic bending solution. The innovative machine concept combines productivity, accuracy, flexibility and reliability with high respect to ecological aspects.

APES **Servo** offers you both sustainability and manufacturing efficiency and productivity which means greater versatility, lower power consumption, less maintenance and no oil to purchase and get rid of it. Easy programming and outstanding accuracy eliminate waste production and lead you better sheet metal component at lower cost.



## User Friendly

Easy to install, use and maintain

---



## Modular

Capable of meeting any production need, with a variety of possible configurations

---



## Energy Efficient

Less energy required and lower environmental impact

---



## Productive

High productivity due to reduced cycle times and higher process reliability

---



## Flexible

Suitable for a wide range of different products

# Headlines to enhance Your **Worklife**



## THE PROFIT

### Energy saving

50 % lower consumption than hydraulic brakes on an average

### Productivity

- Thanks to the high dynamic electro mechanic drive system and "FIESSLER" safety 30% shorter cycle times on an average
- Quick change tooling system, sophisticated on and off-line programming possibilities and intuitive touch screen machine interface guarantee short set-up times
- High reliability thanks to missing hydraulic

### Part Quality

- High repeating accuracy due to
- Rigid O-frame construction
- Servo electrically driven upper beam
- Absence of thermal influence of hydraulic oil
- Sophisticated tooling system

### Low maintenance Cost

- Fewer critical components than in hydraulic machines



## THE FOOTPRINT

Less energy and waste of material  
- less CO<sub>2</sub>

No hydraulic oil  
- no hazardous waste

Easy programming and high accuracy  
-less waste parts

Higher productivity  
-less machinery for the same production

# Design Concept

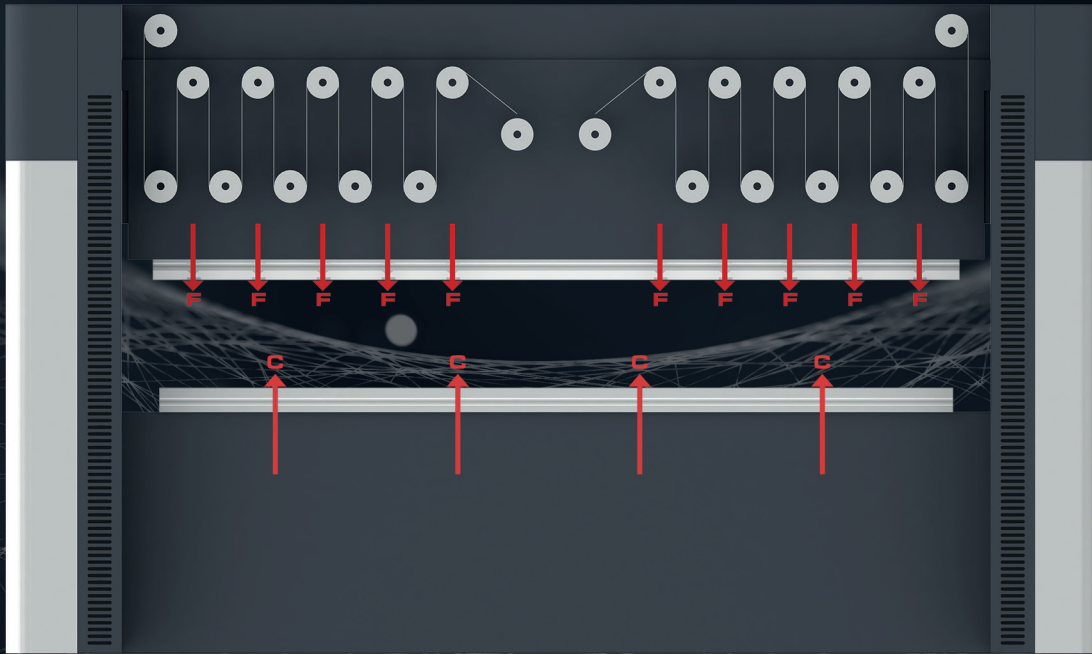

O - Type Body



C - Type Body



## O-FRAME DESIGN

More stable, stronger and produces less deformation in ram and bed.



Industry 4.0  
**READY**

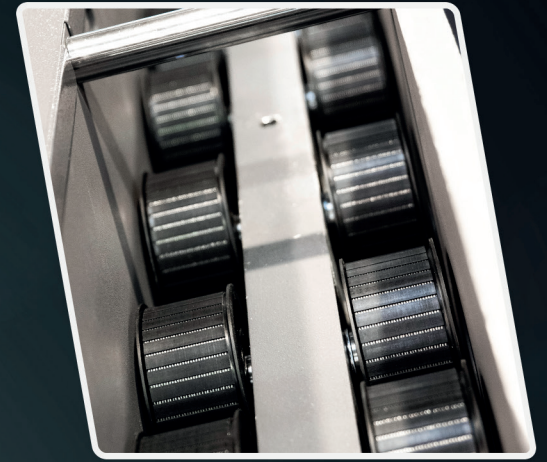



## EFFICIENCY

Extra ordinary performance with  
faster bendings and process optimization

# High Reliability and Maximum Productivity



Time Cycle  
Comparison

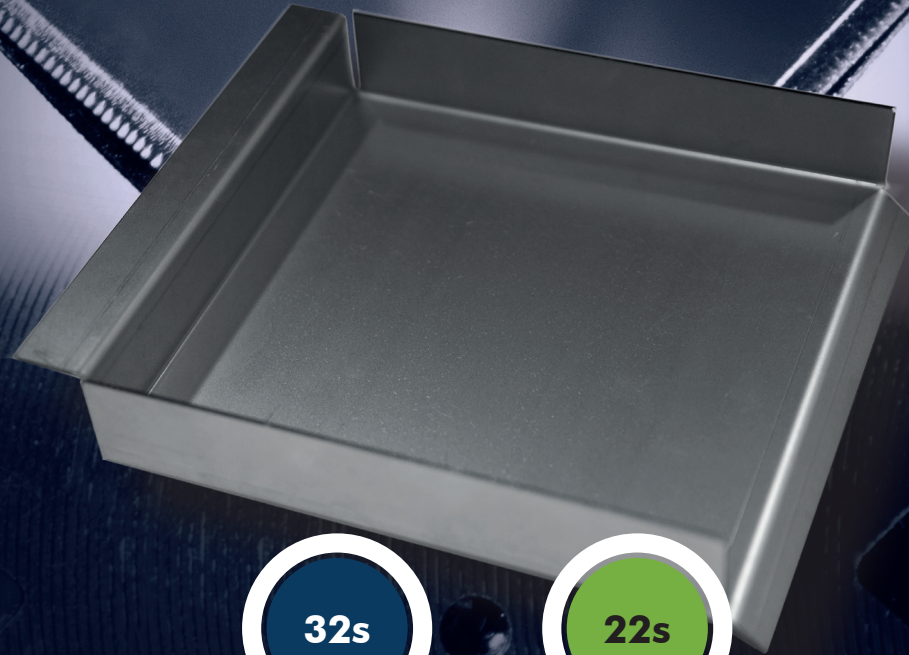

100t Hydraulic  
180 mm/s



APES-Servo mm/s  
110 mm/S

Entire bed length to work

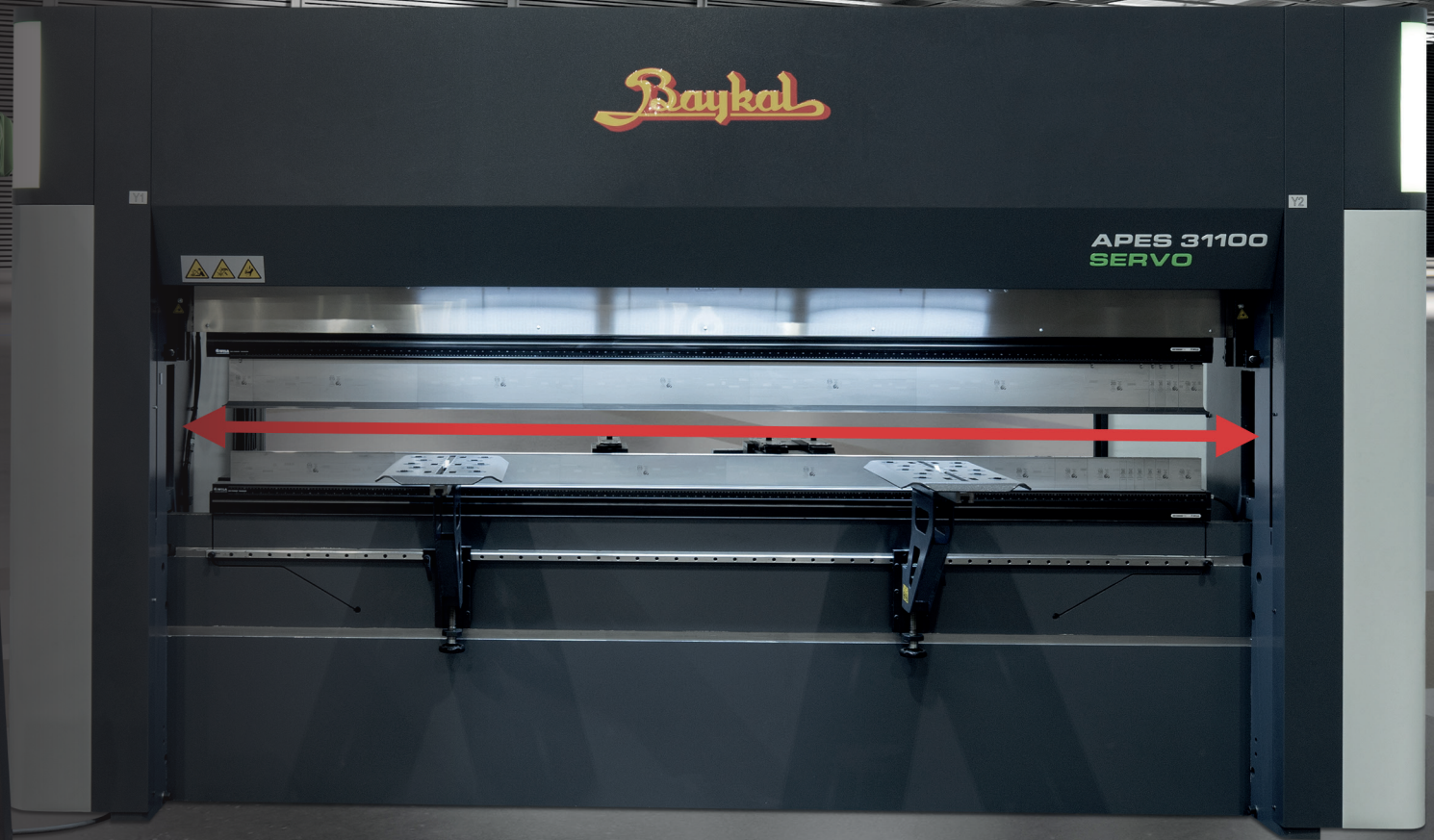

**NO THROAT DEPTH OBSTACLE**



Baykal

APES 31100  
SERVO

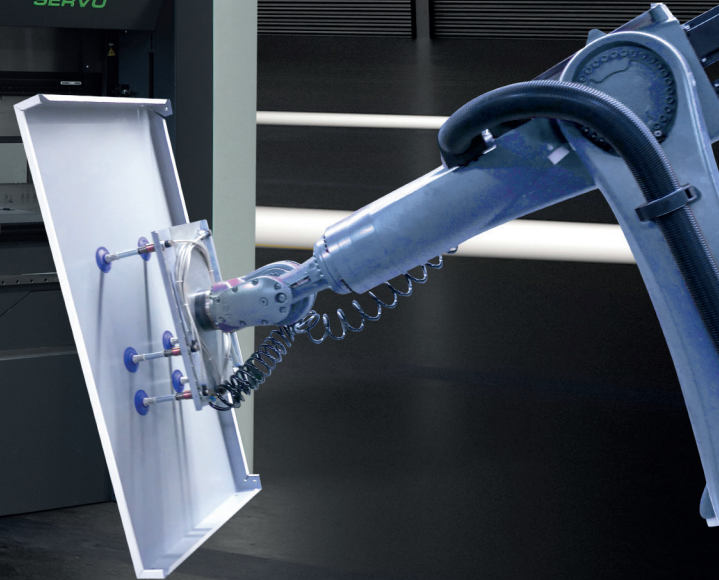
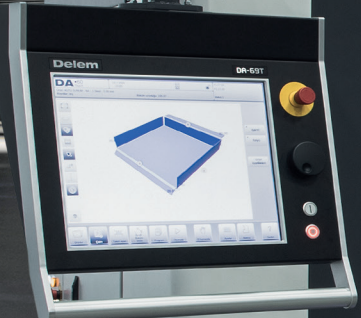

**AUTOMATION**

Ready for robotic applications



*Baykal*

APES 31100  
SERVO

Deltem  
DA  
DR-15T



**INNOVATIVE**

**Lead to Lean Manufacturing and Ready for Industry 4.0**



APES 31100  
SERVO



## INTEGRATED SAFETY

Front and Rear Safeguarding systems allow safe operation

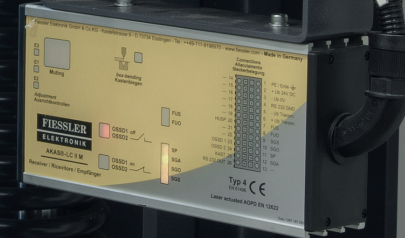





**SPRING COILS PACK**

**Leads Highest Positioning Accuracy**



## **BELT AND PULLEY DRIVE SYSTEM**

**Even distribution of tonnage entire bed length /  
no crowning needed**



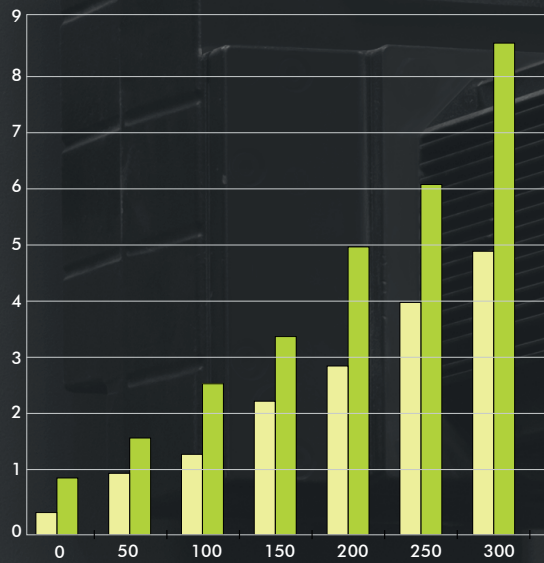

■ E-Brake ■ Conventional

**Energy Consumption**



**ELECTRIC**

**%100 Electric / Fully Electric Drive**



**MOVAEABLE AND ADJUSTABLE SUPPORT ARMS**

**A Range of Support Arms for Light- and Heavy-Duty- Sheet Metal-Work**



**EXTREMELY STABLE BACKGAUGE**

Servo driven (Fast) and CNC controlled (Stable) multiple backgauge configurations from 2 to 6 axis



**ERGONOMICS**

Full Control of Operations with one finger



Delem

DA-60



## OFFLINE 3D PROGRAMMING AND BENDING SIMULATION

3D Offline Programming leads determination of correct results, optimum bending sequence, stop positions and optimum tool set-up



## Perfection at details

Best bending results with Baykal Press Brakes even at hardest bends.



### Easy

Easy to  
Learn

### Innovative

Precision with  
Innovative Industry 4.0

### Flexible

Flexible Solutions  
for All Needs





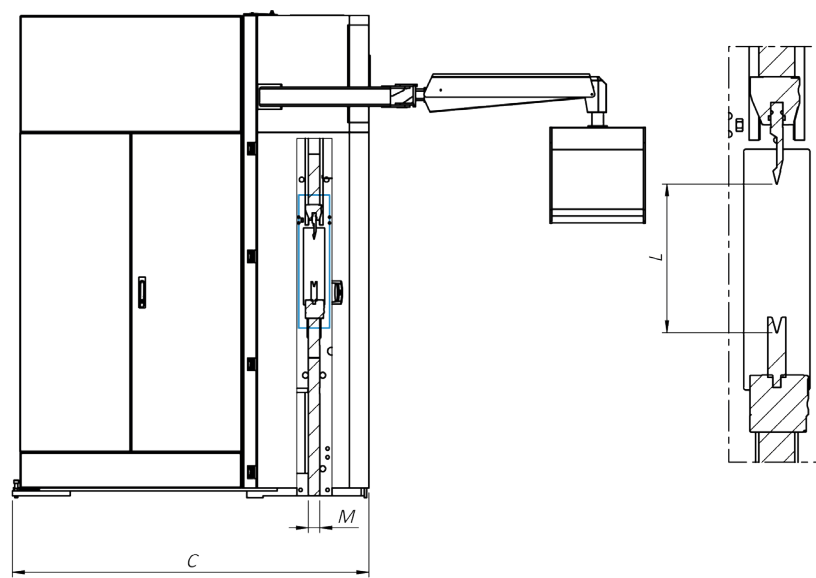
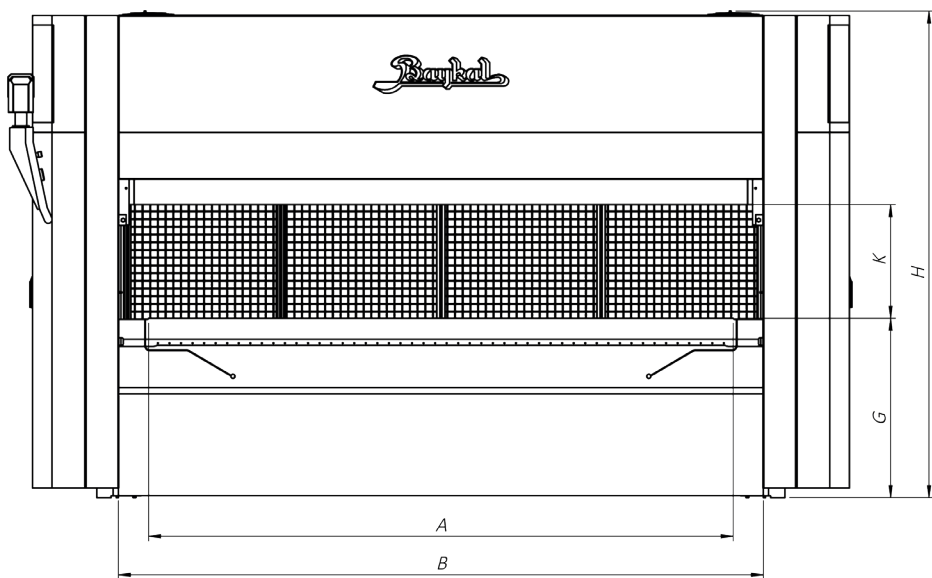
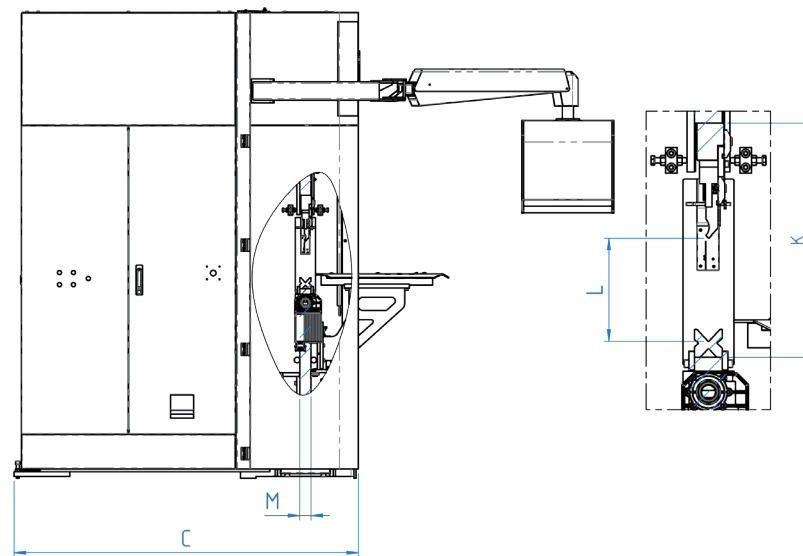
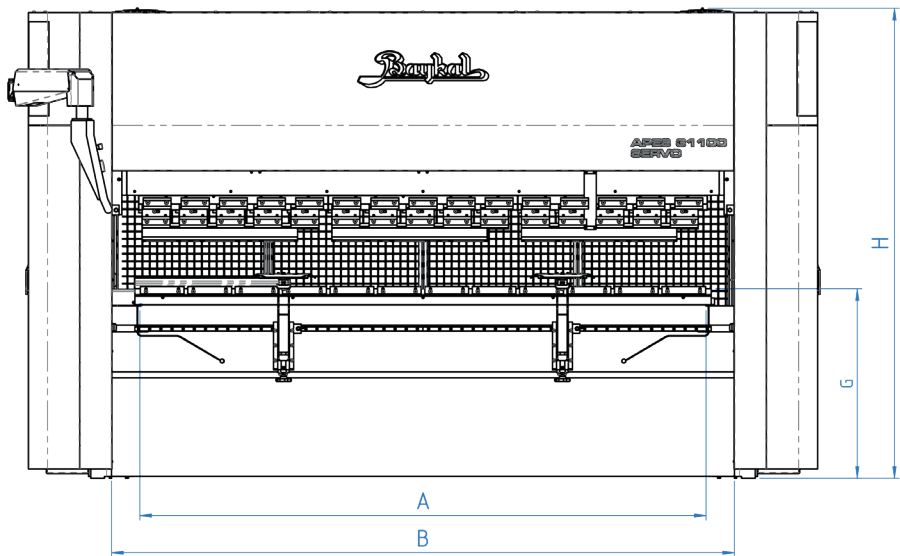

## TECHNICAL DATA

Model	APES Servo Electric Press Brake "Belt&Pulley"				
No	#	SERVO 15040	SERVO 20050	SERVO 26080	SERVO 31100
Bending Force		40 Tons	50 Tons	80 Tons	100 Tons
Motor Output (Power)		2x5.5 kW	2x5.5 kW	2x5.5 kW	2x5.5 kW
Bending Length	A	1530 mm	2040 mm	2550 mm	3050 mm
Inside Frames	B	1790 mm	2300 mm	2810 mm	3350 mm
Side Frame Width	C	1850 mm	1850 mm	1850 mm	1850 mm
Machine Height	H	2525 mm	2525 mm	2525 mm	2525 mm
Bed Height	G	930/(1015*) mm	930/(1015*) mm	930/(1015*) mm	930/(1015*) mm
Daylight Opening	K	590/(505*) mm	590/(505*) mm	590/(505*) mm	590/(505*) mm
Max. Stroke Adjustment	L	300/(240*) mm	300/(240*) mm	300/(240*) mm	300/(240*) mm
Table Width	M	60 mm	60 mm	60 mm	60 mm
Throat Gap		O Frame	O Frame	O Frame	O Frame
Approach Speed		170 mm/s	150 mm/s	90 mm/s	75 mm/s
Working Speed		10/20** mm/s	10/20** mm/s	10/20** mm/s	10/20** mm/s
Return Speed		170 mm/s	150 mm/s	90 mm/s	75 mm/s
Approximate Weight		4.800 Kgs	5.600 Kgs	6,400 Kgs	7,200 Kgs

\* With Promecam Clamping combination.

\*\* Accordance with local regulations, except for Robotic use.

Legal Notice:

Machines built with CE-safety conformity are available as option. Design and specifications are subject to change without notice.

Ö.S.B. Lacivert Cd. 2.Sk. No.1/A 16140 Nilüfer BURSA/TURKEY  
T : +90 224 294 77 00 F : +90 224 243 12 86  
E-mail : baykal@baykal.com.tr  
f @ y / BaykalMachinery